

MATERIAL

Glass-fibre reinforced polyamide based (PA) technopolymer, black colour, matte finish.

STANDARD EXECUTIONS

Black-oxide steel boss, H7 reamed hole, fitting to shaft by means of a supplied grub screw with hexagon socket and cup end UNI 5929-85.

- **MBT-GXX:** for gravity indicators.

- **MBT-PXX:** for positive drive indicators.

Rear flange with internal crown gear wheel in acetal resin based (POM) technopolymer. Black-oxide steel screw and anchor pin.

ERGONOMY AND DESIGN

The particular knurling on the outside rim of the knob, provided with a structure of very fine pitch, allows a safe and comfortable grip, offering the operator the possibility of operating under the most different working conditions in a sensitive and ergonomic way and simplifying the adjustment of the knob during rapid rotation (or screwing) without any unpleasant angular work for the hand and wrist.

INDICATOR CHOICE (TO BE ORDERED SEPARATELY)

To choose the indicator see the table below for possible assembly with indicators. See also "Assembly instructions" for gravity indicators type G (on page 554) or positive drive indicators type P (on page 556).

ACCESSORIES ON REQUEST

Cover CP-XX (see page 581) for fitting instead of the indicator.



ELESA Original design

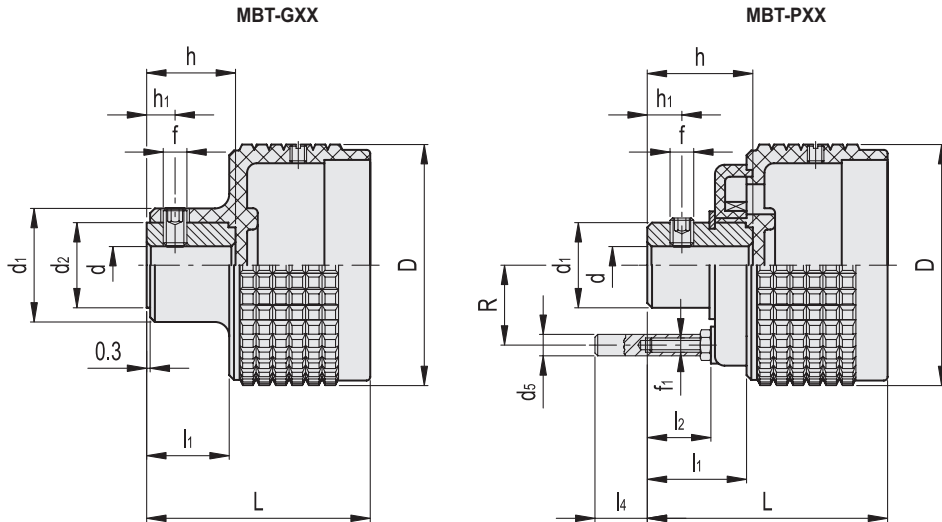

Conversion Table	
1 mm = 0.039 inch	
D	
mm	inch
58	2.28
77	3.03

MBT-GXX

Code	Description	D	L	dH7	h	d1	d2	f	h1	l1	Indicator combinations
CE.30001-R	MBT.60-GXX1 A-8	58	52.5	8	17	24	18	M5	6	17	GA01 - GA11
CE.30051-R	MBT.80-GXX2 A-10	77	61	10	22	28	22	M5	6	22	GA02 - GA12 - GW12

MBT-PXX

Code	Description	D	L	dH7	h	d1	d5	f	f1	h1	l1	l2	l4	R	Indicator combinations	
CE.30002-R	MBT.60-PXX1 A-8	58	55	8	20.5	18	6	M5	M4	5	18.5	10.5	14.5	19	87	PA01 - PA11
CE.30052-R	MBT.80-PXX2 A-10	77	59	10	22	30	6	M5	M4	6	20	12	13	28.5	218	PA02 - PA12 - PW12